

INSTRUCTION MANUAL

ELECTRIC TROLLEY

RASCAMAT®
3arm®

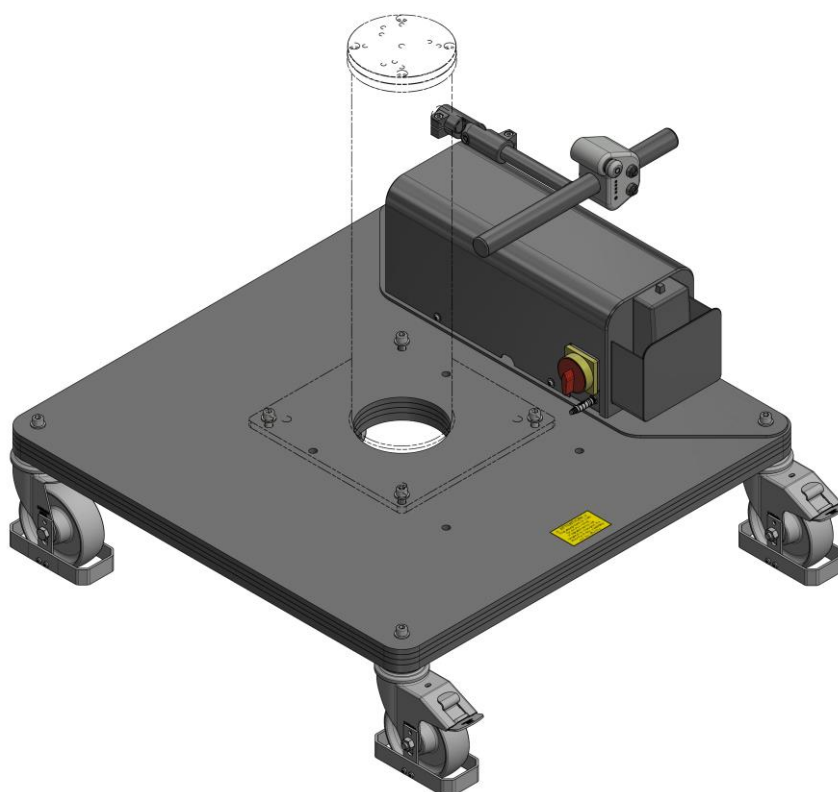

TECNOSPIRO MACHINE TOOL, S.L.U.

P.I Pla dels Vinyats I, s/n nau 1

08250 - Sant Joan de Vilatorrada. Barcelona - España

Telf. +34 938 76 43 59

E-mail: roscamat@roscamat.com

3arm@3arm.net

ISO 9001
BUREAU VERITAS
Certification



TECNOSPIRO
MACHINE TOOL SLU



www.roscamat.com
www.3arm.net

TABLE OF CONTENTS

1	INTRODUCTION.....	4
2	ABOUT THIS MANUAL	5
2.1	CONSIDERATIONS.....	5
2.2	DOCUMENT VERSION	6
3	SAFETY INFORMATION.....	6
3.1	SCOPE OF APPLICATION.....	6
3.2	WARNINGS AND GENERAL CONSIDERATIONS	6
3.3	EXCLUSIONS	7
3.4	SYMBOLS AND ICONS	8
3.5	PERSONAL PROTECTION EQUIPMENT (PPE)	8
3.6	TRAINING LEVEL OF THE STAFF INVOLVED.....	8
4	GENERAL DESCRIPTION AND TECHNICAL INFORMATION	9
4.1	MAIN PARTS.....	9
4.2	DIMENSIONS.....	10
4.3	CONFIGURATIONS	12
4.4	MOVEMENTS	13
4.5	REACTION TORQUE	14
4.6	TECHNICAL SPECIFICATIONS	15
4.7	IDENTIFICATION	15
5	INSTALLATION	16
6	ADJUSTMENTS	17
6.1	ADJUSTING THE HANDLEBAR HEIGHT.....	17
6.2	ADJUSTING THE SPRING	18
7	OPERATION	19
7.1	HANDLING AND USE.....	19
7.2	RECHARGING THE BATTERY	20
7.3	COLOUR CODING.....	21
8	MAINTENANCE.....	22
8.1	TIGHTENING THE SCREWS	22
8.2	WHEELS.....	22
8.3	BATTERIES.....	22
8.4	GENERAL CLEANING	22
8.5	MAINTENANCE TABLE	23
8.6	REPLACING THE BATTERY	24
8.7	SOFTWARE UPDATE	25
9	FREQUENT PROBLEMS	26

9.1	PROBLEM: ENGINE WON'T START	26
9.2	PROBLEM: THE WHEEL SKIDS.....	26
9.3	PROBLEM: WRONG SPEED	26
9.4	PROBLEM: OVERCURRENT.....	26
9.5	PROBLEM: SHORT-CIRCUIT	27
9.6	PROBLEM: FAULTY BATTERIES.....	27
9.7	PROBLEM: NO BATTERY	27
10	WIRING.....	28
10.1	MAIN WIRING	28
10.2	ELECTRICAL DIAGRAM	29
11	SPARE PARTS.....	30
12	ACCESSORIES.....	31
12.1	COMPATIBLE ACCESSORIES	34
12.2	COMPATIBLE EQUIPMENT.....	34
13	WARRANTY.....	34
14	PACKAGING, TRANSPORT AND DISASSEMBLY GUIDELINES	35
14.1	PACKAGING	35
14.2	TRANSPORT.....	35
14.3	DISASSEMBLY.....	35
	CE STATEMENT OF COMPLIANCE	37

1 INTRODUCTION

Dear customer,

We would like to congratulate you on your choice and we are pleased to continue our constant work to provide our customers with a simple, reliable and versatile way to improve ergonomics in the workplace.

We hope these simple instructions will help you to set up and operate the equipment you have selected. We suggest you pay special attention to the pages on the concepts of installation, maintenance and safety.

We wish a long life to your equipment and we hope that you can confirm the very good investment made in purchasing an electric trolley compatible with 3arm[®] and ROSCAMAT[®] products.

2 ABOUT THIS MANUAL

This document corresponds to the Electric Trolley instruction manual.

- ORIGINAL MANUAL -

Intellectual/Industrial Property Information:

Tecnospiro Machine Tool, S.L.U. (the Company) informs that all content in this document including, for example, the text, images, graphic designs, brands, trading and company names (hereinafter, the Intellectual/Industrial Property), belong to the Company and that the Company is the exclusive owner of their use. Copying, reproduction, distribution, public communication and total or partial use of the Intellectual/Industrial Property, in any form or manner, even quoting the sources, is prohibited, unless expressly agreed in writing by the Company. The use of any content that due to its characteristics is similar to the Industrial/Intellectual Property is also considered an infringement of the Company's Industrial/Intellectual Property rights.

2.1 CONSIDERATIONS

- ✓ Before using the equipment, be sure to read this instruction manual and follow the use and safety instructions correctly.
- ✓ All the instructions listed in this manual refer to the individual unit. It is the end user's responsibility to analyse and apply all the necessary safety measures required for the end use.
- ✓ This manual must be kept for the entire life of the equipment, in a place close to it for future reference.

- ✓ If any part of this manual is unclear, confusing or inaccurate, please do not hesitate to contact us.
- ✓ The content of this manual may be subject to change without prior notice.
- ✓ If the manual is lost or damaged, contact TECNOSPIRO MACHINE TOOL, S.L.U. for a replacement.
- ✓ Reproducing or sharing this documentation – or part of it – to third parties is only permitted with express written authorisation from TECNOSPIRO MACHINE TOOL, S.L.U.
- ✓ The illustrations shown in this manual may differ in some details from their specific configuration and should be understood as a standard representation.

Paragraphs indicating assembly, adjustment, installation or maintenance steps are framed with a brown background.

Paragraphs with highlighted information are framed with a grey background.

2.2 DOCUMENT VERSION

Document	Date - version
Instruction manual Electric Trolley	10/25/2023

3 SAFETY INFORMATION

3.1 SCOPE OF APPLICATION

This chapter contains very important information related to the safety of your equipment; it is aimed at all staff involved in any of the life stages of this equipment (transport, assembly, installation, commissioning, adjustment, learning, operation, cleaning, maintenance, troubleshooting, dismantling/decommissioning).

3.2 WARNINGS AND GENERAL CONSIDERATIONS

- ✓ The equipment described in this document has been built in accordance with the current technological level and pursuant to the applicable technical standards in terms of safety. However, improper use, or incorrect integration by the end user can generate risk of injury.
- ✓ The equipment must only be used in perfect technical condition, respecting the safety regulations and the instructions provided in this document.
- ✓ Any breakdown that may affect safety must be corrected immediately.
- ✓ Without the proper authorisation of TECNOSPIRO MACHINE TOOL, S.L.U.

No modification of equipment should be made.

- ✓ The equipment must only be operated for its intended use. Any other use is strictly prohibited. Any use other than that indicated is considered misuse and is prohibited. The manufacturer assumes no liability for damages that may arise from it. This is solely at the user's own risk.
- ✓ It is the responsibility of the integrator, owner and/or end user to determine the suitability of the product for each use, as well as its place of installation and the specific definition of the task to be carried out with this product within the limits stated in this manual.
- ✓ Do not use the equipment in any way that is not considered in this manual and pay special attention to the uses mentioned in section 3.3 EXCLUSIONS, which must not be carried out.
- ✓ The operator must only use the equipment after having received the instructions for its use.
- ✓ Do not exceed the maximum working loads indicated in this manual as well as in the identification on the equipment structure.
- ✓ It is recommended that only one operator use the equipment at a time, any other use must be evaluated by the integrator/end user.
- ✓ When not in use, it should be left in the braking position.

- ✓ The operator may only use the equipment for safe movements, accompanying the movement of the equipment at all times, and thus reducing the risk of uncontrolled or involuntary movements.
- ✓ The work area of the equipment and its surrounding area must respect conditions of safety, health and hygiene at work. It is the integrator/end user's responsibility to conduct a study to guarantee safety.
- ✓ The presence of third parties in the work area of the equipment should be restricted as much as possible, thus avoiding any impact on safety. For any other use, an additional study of the hazards derived from this way of working must be carried out.
- ✓ Only authorised personnel may be present in this area while the equipment is in use.
- ✓ It is important that the users who operate this equipment are familiar with and sufficiently trained to use this product or similar products.
- ✓ It is recommended that the operator have basic knowledge of: Safety procedures, precautions and safe working habits.
- ✓ In any case, the operator must read and understand this manual before use regardless of their knowledge, training or experience with similar equipment, especially the sections dedicated to installation, operation and safety.
- ✓ To the perimeter of the equipment, you must add the opportune distance to allow people to walk around it safely. Work areas must remain free from obstacles, columns, etc. that may hinder the operators' work.
- ✓ Suitable spaces must be available to carry out maintenance, adjustment, cleaning, etc. tasks.
- ✓ If you have questions about handling or maintenance procedures, please contact the authorised technical service.
- ✓ It is forbidden to climb on the trolley during its use.







3.3 EXCLUSIONS

The following is beyond the scope of use of this equipment:

- ✓ Handling of any component or functions of the equipment outside of those specified in this manual.
- ✓ Use by people with some type of disability or by animals.
- ✓ Use by people without a completed course on labour risks prevention.
- ✓ Loads greater than the maximum working load limits (WLL).
- ✓ Operation in severe conditions (e.g. extreme environmental conditions such as freezing, high temperatures, corrosive environment, strong magnetic fields, high humidity)
- ✓ Use in areas with risk of explosion.
- ✓ Installation in outdoor areas.

3.4 SYMBOLS AND ICONS

Throughout this manual and in the structure of the machine, different symbols and pictograms can be observed, the meaning of which is summarised below.

	General danger symbol. It is usually accompanied by another symbol, or a more detailed description of the danger.
	Trapping hazard
	Electrical hazard
	Danger, hot surface
	Danger, explosive material
	Danger, corrosive substance
	Do not climb

3.5 PERSONAL PROTECTION EQUIPMENT (PPE)

Personal protective equipment for the equipment is reduced to safety footwear, for all stages of the equipment's life.

It is the integrator/end user's responsibility to define the personal protection equipment derived from the final application of the equipment, in order to comply with the essential health, safety and hygiene requirements.

Operators must not wear loose clothing, rings or bracelets that may fall within the equipment's mechanism.

It is also mandatory to wear the hair collected to avoid snags with the moving parts of the equipment.

3.6 TRAINING LEVEL OF THE STAFF INVOLVED

All people working with the equipment must have read and understood the safety chapter in the documentation.

The minimum training level required to use the equipment is:

- Production workers: labour risks prevention course, full training on the workstations and the residual risks of the equipment. Minimum one year's experience in similar facilities.
- Maintenance workers: Labour risks prevention course, full training on the handling, operation, maintenance and conservation of the equipment and residual risks. Minimum of two years' experience in similar facilities and with the necessary technical level to perform tasks without problems.
- Cleaning operators: Course on labour risks prevention, training in the products and procedures for carrying out cleaning tasks.
- Apprentices/students: They may only work on the equipment under the supervision, at all times, of a person responsible for the installation.
- Public (non-operators): Visitors or passers-by must maintain a minimum safety distance of two metres from the edges of the perimeter of the equipment.

4 GENERAL DESCRIPTION AND TECHNICAL INFORMATION

This Electric Trolley was designed to be used with 3arm® and ROSCAMAT® products, as well as compatible accessories, providing greater mobility to your 3arm® or ROSCAMAT® equipment in an easy and safe way. The operator can control the movement of the trolley and direct it by means of the handle.

The 3arm® electric trolley is designed to move your 3arm equipment within an industrial environment, on a flat surface, and place it precisely in certain working positions.

4.1 MAIN PARTS

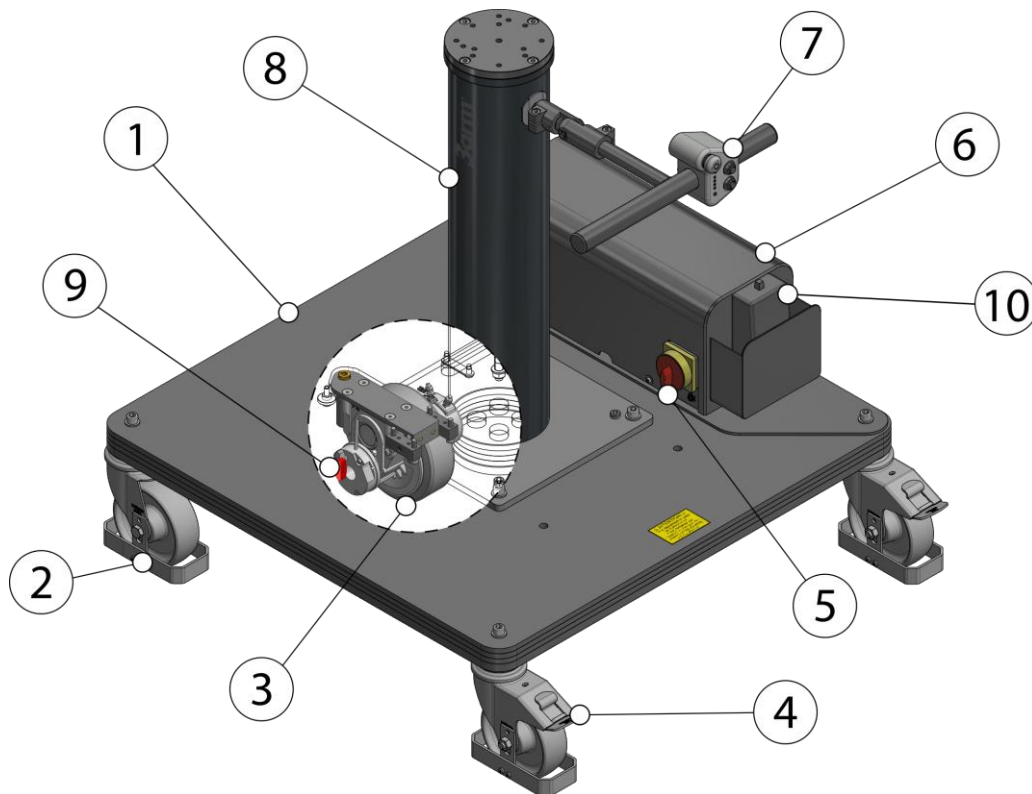

- | | |
|----------------------|-------------------------|
| 1.- Trolley | 7.- Controls |
| 2.- Unbraked wheel | 8.- Column ¹ |
| 3.- Electric wheel | 9.- Drive wheel |
| 4.- Wheel with brake | unlock key |
| 5.- Main switch | 10.- Battery charger |
| 6.- Battery | |

¹ The column is not included in the trolley. It is a standard accessory element, supplied separately, which will be defined by the customer according to catalogue lengths.

4.2 DIMENSIONS

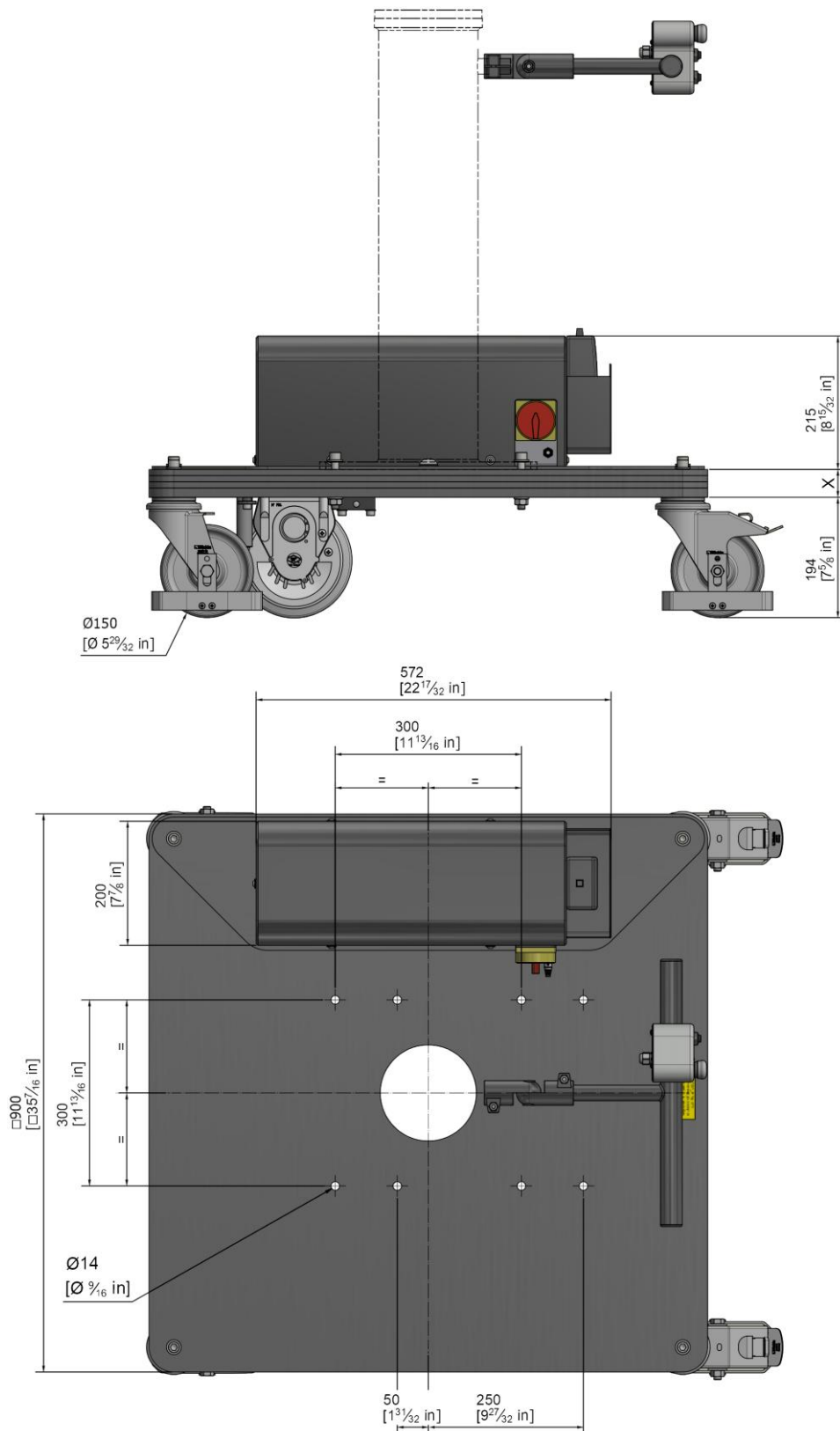

Electric trolley - 900x900

The thickness of the trolley should be chosen depending on the configuration in which it will be integrated to ensure the stability of the set. X will vary depending on the stability calculation of the assembly ($X_{\min} = 25\text{mm}$).

4.3 CONFIGURATIONS

This electric trolley has been designed to be used in combination with 3arm® and ROSCAMAT® products, as well as 3arm® compatible accessories, to give them greater mobility.

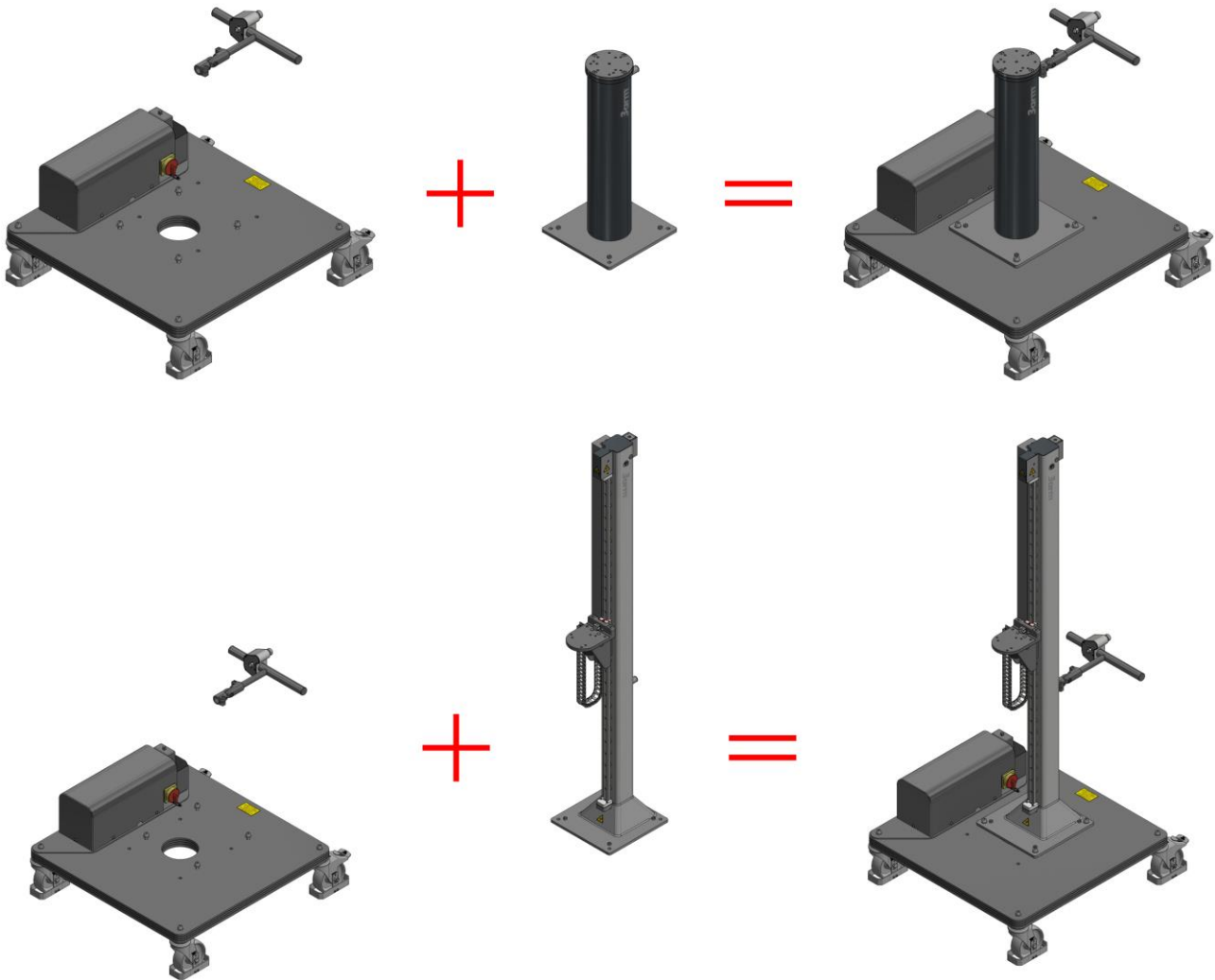

4.4 MOVEMENTS

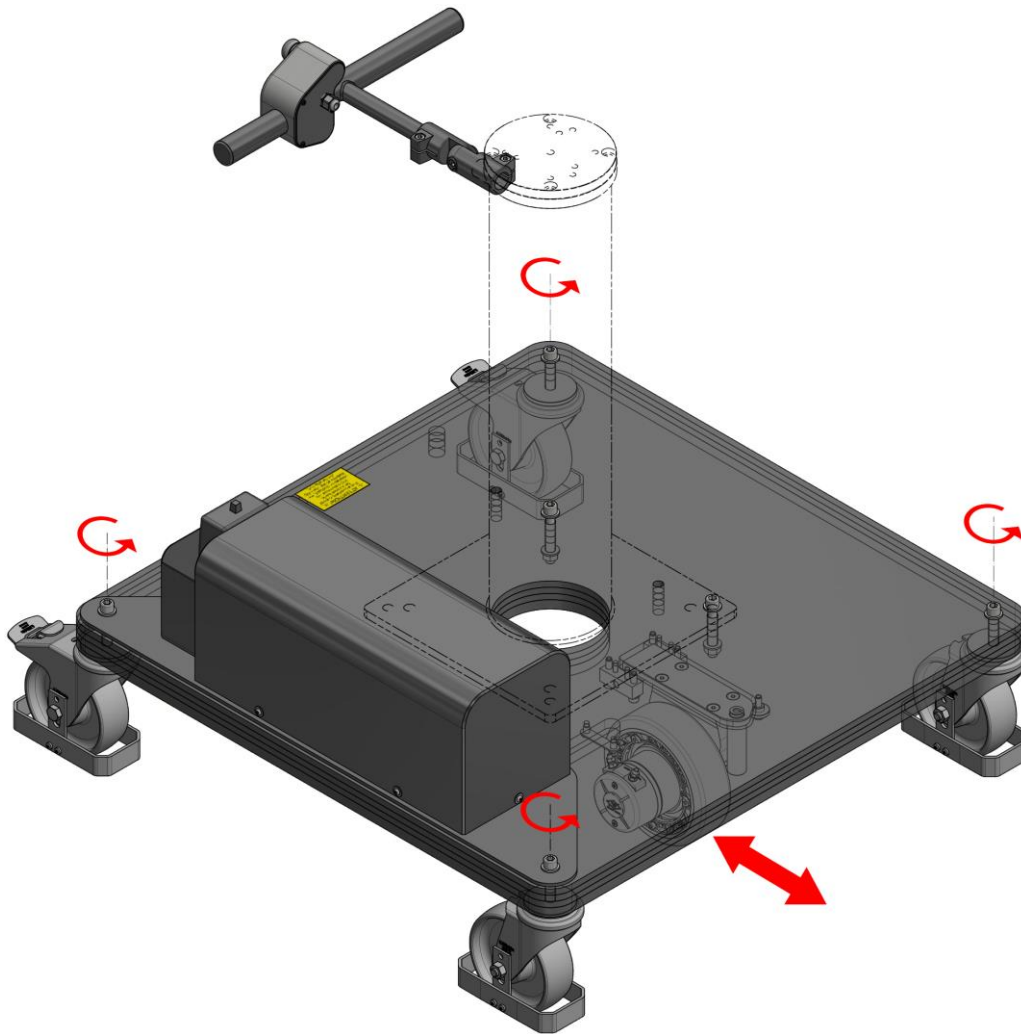

- 4 caster wheels (2 with brakes)
- One driving wheel

4.5 REACTION TORQUE

The electric wheel has a built-in brake that is always active (the brake is deactivated when the trolley is running), however, if you mount a reaction tool on the trolley you must brake the rear wheels to prevent the trolley from turning:

1. Press the lever (1) until it locks. On both rear wheels.

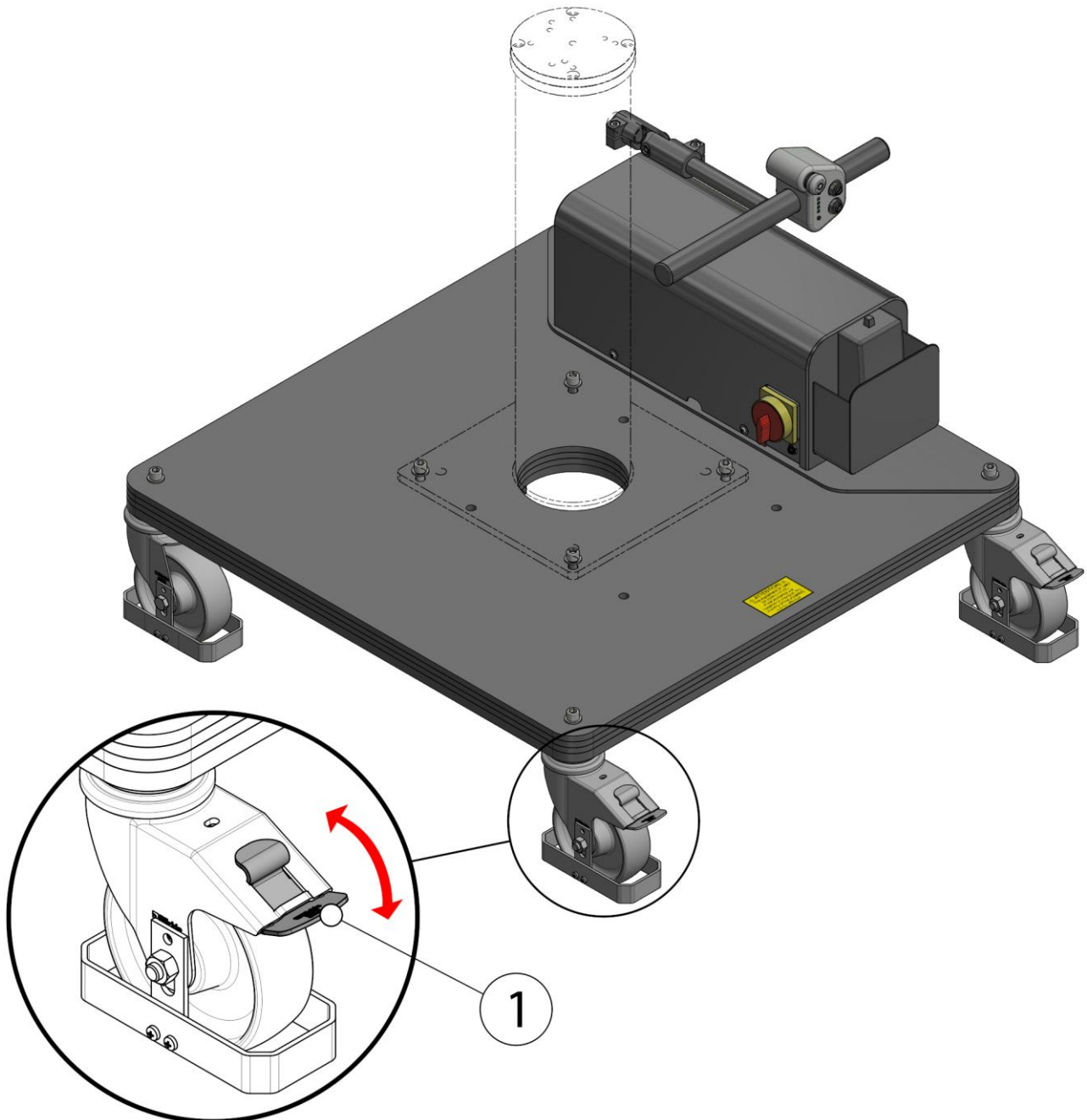

4.6 TECHNICAL SPECIFICATIONS

GENERAL TECHNICAL SPECIFICATIONS		
Load capacity		
	Maximum towable weight	1400 Kg (3086 lbs)
Speed		
	Slow	1 Km/h
	Fast	2.5 Km/h
Electrical specifications		
	Power supply voltage	100-240Vac 50-60Hz
	Operating voltage	24V
	Power	350 W
	Protection class	IP54
Battery		
	Battery capacity	26Ah
	Charging time	4 – 6 h
	Minimum operating distance ²	6 Km
Working and storage conditions		
	Temperature	0 °C to +45°C
	Relative humidity	Max. 70%
	Environment	Industrial environments
	Noise	66.7 dB
	Illumination min. workstation	500 lux
	Illumination min. circulation	150 lux
	Vibrations	Less than 2.5m/s ²
	Surface	Smooth, horizontal, firm and anti-slip

4.7 IDENTIFICATION

A sticker next to the structure identifies your equipment and indicates the following characteristics.

CE and UKCA marking, Manufacturer (name, address and business name), Date of manufacture, Serial number, Model, Name, Maximum working load, Empty load, Voltage, Power and Battery.



² With new, 100% charged batteries

5 INSTALLATION



INSTALLATION

- ✓ The 3arm® electric trolley is designed to work on a smooth, horizontal, firm and non-slip surface.
- ✓ This trolley has been designed for use together with 3arm® and ROSCAMAT® products, as well as 3arm® and ROSCAMAT® compatible accessories. In any case, the integrator, owner and/or end user is responsible for determining the product's suitability for each use, the installation location, specifically defining the task to be performed within the limits set forth in this manual.

1. Use the eyebolts (1) to remove the trolley from its original packaging.
2. Remove the eyebolts (1) and install the column³ on the trolley with the screws (2) (10mm Allen key) and the nuts (3) (19mm Socket wrench).
3. Place the handlebar (5) on the column and tighten the screw (4) (6mm Allen key).
4. Charge the battery [See RECHARGING THE BATTERY page 20].

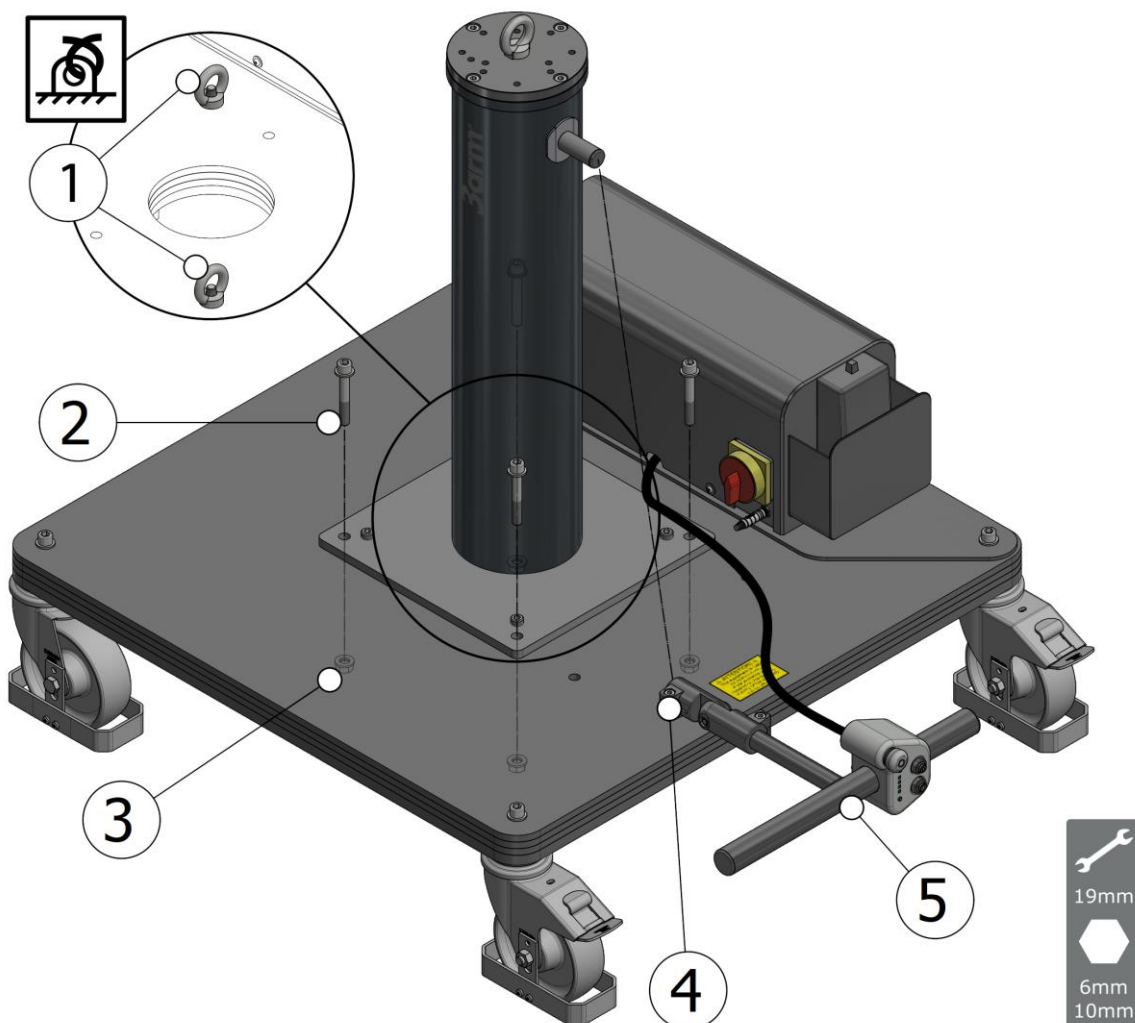

³ See attached manual of the lifting column for its location on the trolley.

6 ADJUSTMENTS

6.1 ADJUSTING THE HANDLEBAR HEIGHT

To improve ergonomics, the handlebar height is adjustable. To do this:

- 1- Loosen the adjusting screw (1) (6mm Allen key).
- 2- Adjust the position of the handlebars according to your preference and working conditions.
- 3- Tighten the screw (1) firmly (6mm Allen key).

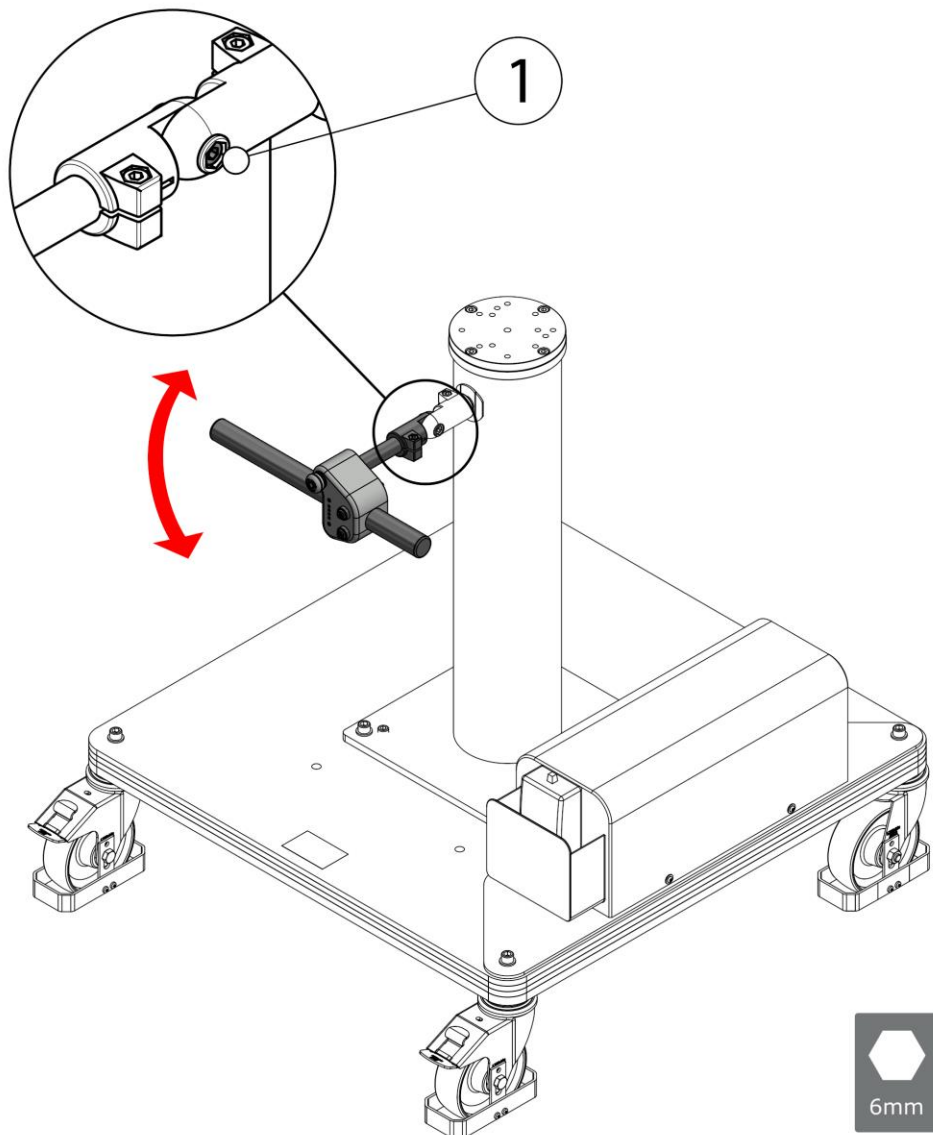

6.2 ADJUSTING THE SPRING

The drive wheel system is set at the factory. If the user does not have good traction on the ground, the traction force can be adjusted using the traction spring controller, indicated in the following section.

1- Adjust the screw (1) at the bottom ⁴of the carriage (8mm Allen key).

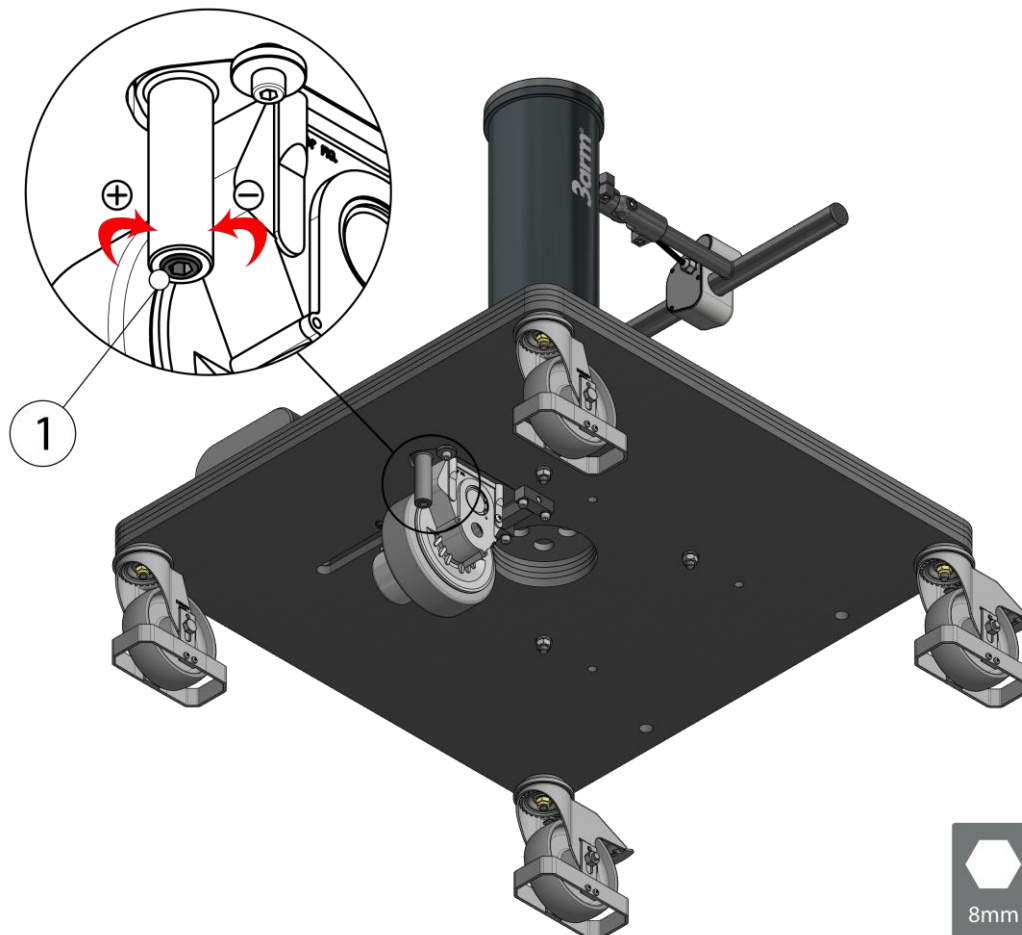

Adjusting the spring's resistance is particularly useful in situations where the surface to be moved is not completely smooth or anti-slip.

CAUTION

✓ The driving wheels must always be in contact with the ground.

⁴ Approximately 20 kg/turn

7 OPERATION

7.1 HANDLING AND USE

The electric trolley has been designed to facilitate the mobility of 3arm® and ROSCAMAT® accessories and equipment. To do this:

- 1- Turn the main switch on (1).
- 2- Check that the emergency stop (2) is not activated.
- 3- Advance or reverse the trolley with the switches (3) and (4) respectively. The operator must steer the trolley by means of the handlebar.
- 4- Turn off the trolley with the main switch (1) at the end of the work period.

The trolley has two feed speeds:

- **Start / maneuver / turtle (slow) (1 Km/h)**
- **Cruise / free (fast) (2.5 Km/h)**

- By pressing the button (3) → slow speed (tortoise) engaged.
- If we keep pressing the button (3), the trolley will automatically change to fast speed (hare).
- Reverse only supports → slow speed (tortoise).

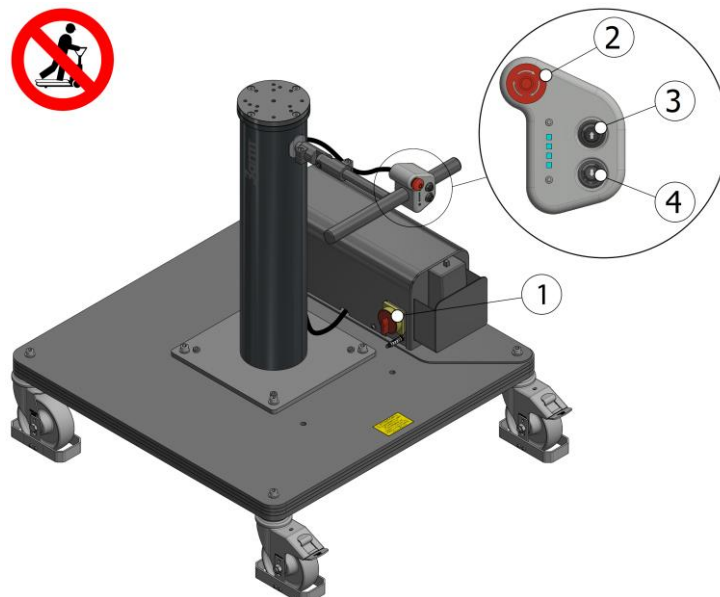

After 1 minute of inactivity the equipment will go into low power mode. Do not leave the equipment in this mode indefinitely, as this option may cause premature battery wear.

When cornering, you must slow down.



CAUTION

- ✓ To operate the trolley you must ensure that the rear wheel brakes are not activated.

7.2 RECHARGING THE BATTERY

When the battery reaches 0% the LEDs will flash ■ [See COLOUR CODING page 21]. The battery must be recharged. To do this:

- 1- Turn the main switch on (1).
- 2- Plug the charger into the power supply.
- 3- Wait 4 - 6 hours until fully charged [See COLOUR CODING page 21].
- 4- Unplug the charger.

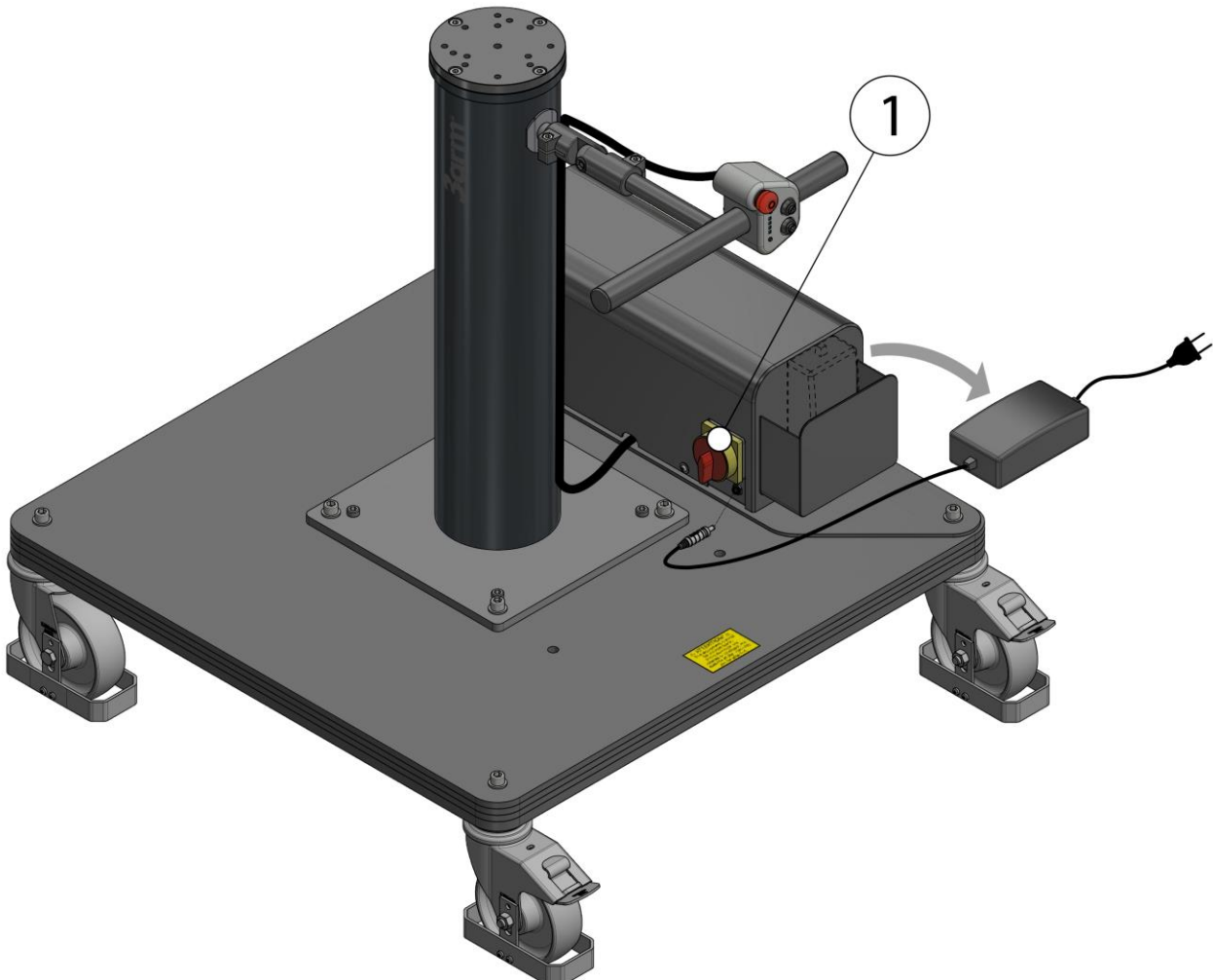

The trolley controls are disabled during the charging process.

The load point must have a 30mA differential switch and a disconnection time of 0.2 seconds.



CAUTION

- ✓ The main switch cuts off the current between the batteries and the trolley, if it is not connected it will not charge.

7.3 COLOUR CODING

On the handlebar, there are 4 LEDs next to the trolley controls that give information about the trolley's status. The following tables detail the possible cases:

		Battery status								
		0% ⁵	0-20%	20-40%	40-60%	>60%	Stop	Overintensity	Short-circuit	Low power (Once every 30s)
Led 1										↔
Led 2										↔
Led 3										↔
Led 4										↔

		Battery charging status				
		0-20%	20-40%	40-60%	>60%	100%
Led 1						Flashing
Led 2						
Led 3						
Led 4						

⁵ 0% of the battery represents a discharge of 50% of the total battery charge to avoid excessive wear in this type of battery.

8 MAINTENANCE

The trolley does NOT require maintenance and, when used properly, anomalies are unlikely to occur. Even so, we detail the main and simple repairs that can be carried out.

8.1 TIGHTENING THE SCREWS

To ensure the equipment functions correctly, it is advisable to check the tightness of all the screws periodically. The recommended period is every 6 months.

8.2 WHEELS

To ensure that the trolley moves properly, check the condition of the nylon wheels. If they are worn, they should be replaced.

8.3 BATTERIES

For a correct operation of the equipment, it is recommended to check the connections, corrosion, cracks, leaks and the presence of sulphates in the batteries. The recommended period is every 6 months.

Failure to use the battery for 3 months will void the battery warranty. Charge the batteries every 3 months, even if they are not used, to keep them in good condition.

Batteries are considered a fungible good so they have no official warranty as they depend on the use made and if it is correct or not. However, any incidents due to a quality problem shall be compensated.

Reinforce this information with the attached battery manual.



BATTERY WARRANTY

✓ To check the warranty period of the batteries, see the attached battery manual.



CAUTION!

Do not discard your batteries in the trash!

The battery has toxic components that can cause damage to health and the environment if improperly disposed of.

Composition: Lead, sulphuric acid and plastic.

8.4 GENERAL CLEANING

It is advisable to carry out a weekly general cleaning of the equipment to maintain a good state of the entire equipment and to extend its useful life.

8.5 MAINTENANCE TABLE

The following table summarises the preventive maintenance tasks that will ensure the proper functioning of the equipment.

The time period detailed in the table corresponds to a normal environment. If your equipment is installed in a dirty environment (foundries, outside, dust, humidity...) you should reduce the interval between maintenance tasks.

DESCRIPTION ELEMENT	ACTION	PERIOD
Screws and fasteners	Check tightening and functionality of the securing elements.	Every six months
Wheels	Check the condition of the nylon wheels and replace them if worn.	Every six months
Batteries	Check the connections, corrosion, cracks, leaks and the presence of sulphates.	Every six months
	Charge the batteries if the equipment is not being used.	Every three months
General cleaning	When dirty, clean with a mild household product. Do not use other cleaning agents, as they can cause damage (on batteries, use water or carbonated water to clean the monoblocks and covers)	Monthly

8.6 REPLACING THE BATTERY



BEFORE REPLACING THE BATTERY

- ✓ The equipment must be duly installed and integrated.
- ✓ Tampering with the battery is prohibited.
- ✓ Do not place tools on the batteries (especially if they are metallic).
- ✓ Use tools with insulated handles to tighten the connections.
- ✓ Both batteries must be replaced.



CAUTION!

- ✓ The trolley is earthed, use extreme caution when handling the positive of the batteries.
- ✓ See battery manual attached.

- 1- Turn the main switch off (1).
- 2- Remove the 6 screws (2) (3mm Allen key) with the washers and remove the cover (3).
- 3- Remove the nuts (4) (13mm socket wrench) and remove the plate (5).
- 4- Remove the nuts (6) (13mm socket wrench) and remove the frame (7).
- 5- First disconnect the positive pole of the batteries (8) (4mm Allen key) and then the negative pole (4mm Allen key).
- 6- Replace the batteries (8) with new ones, first connect the negative (4mm Allen key) and then the positive (4mm Allen key). The battery terminals are threaded at 3Nm.
- 7- Carry out the process in reverse for assembly.

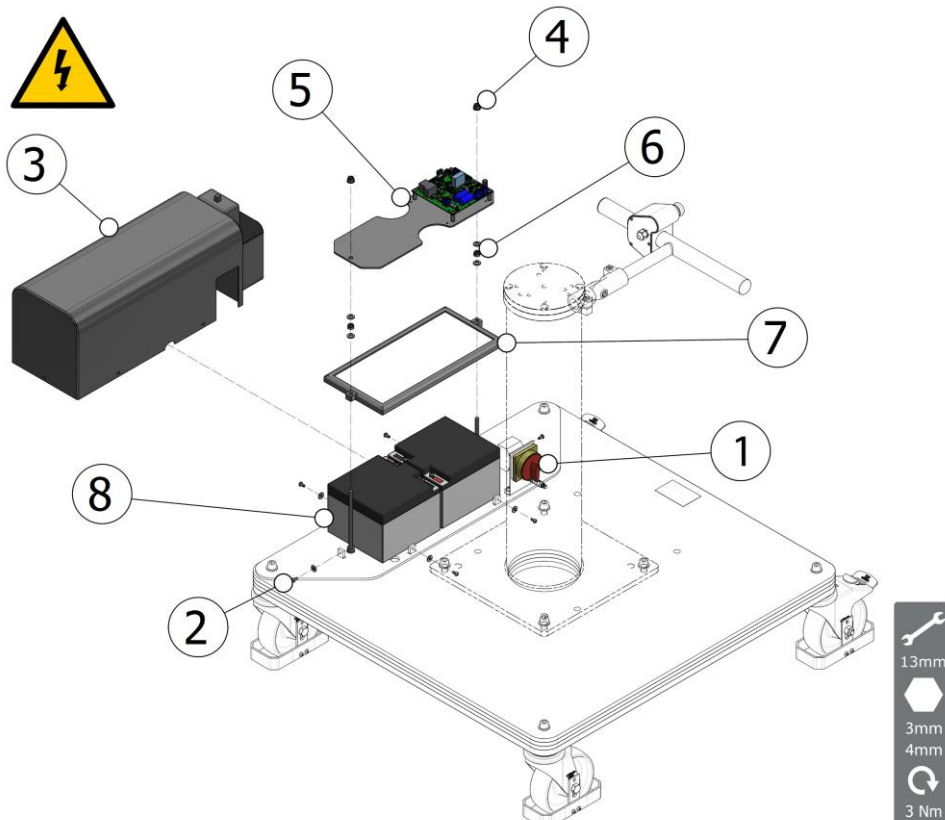

8.7 SOFTWARE UPDATE



BEFORE UPDATING THE SOFTWARE

✓ The equipment must be duly installed and integrated.

- 1- Remove the 6 screws (1) (3mm Allen key) with the washers and remove the cover (2).
- 2- Insert the USB (3) with the software update into J5 on the main PCB [See [ELECTRICAL DIAGRAM page 29](#)].

NOTE: The USB memory should contain only the update file with name SROS130.bin

- 3- Press and hold the button (4) on the main PCB for 5 seconds⁶ to load the update onto the trolley.
- 4- Remove the USB (3), place the cover (2) and attach the washers and screws (1) (3mm Allen key).

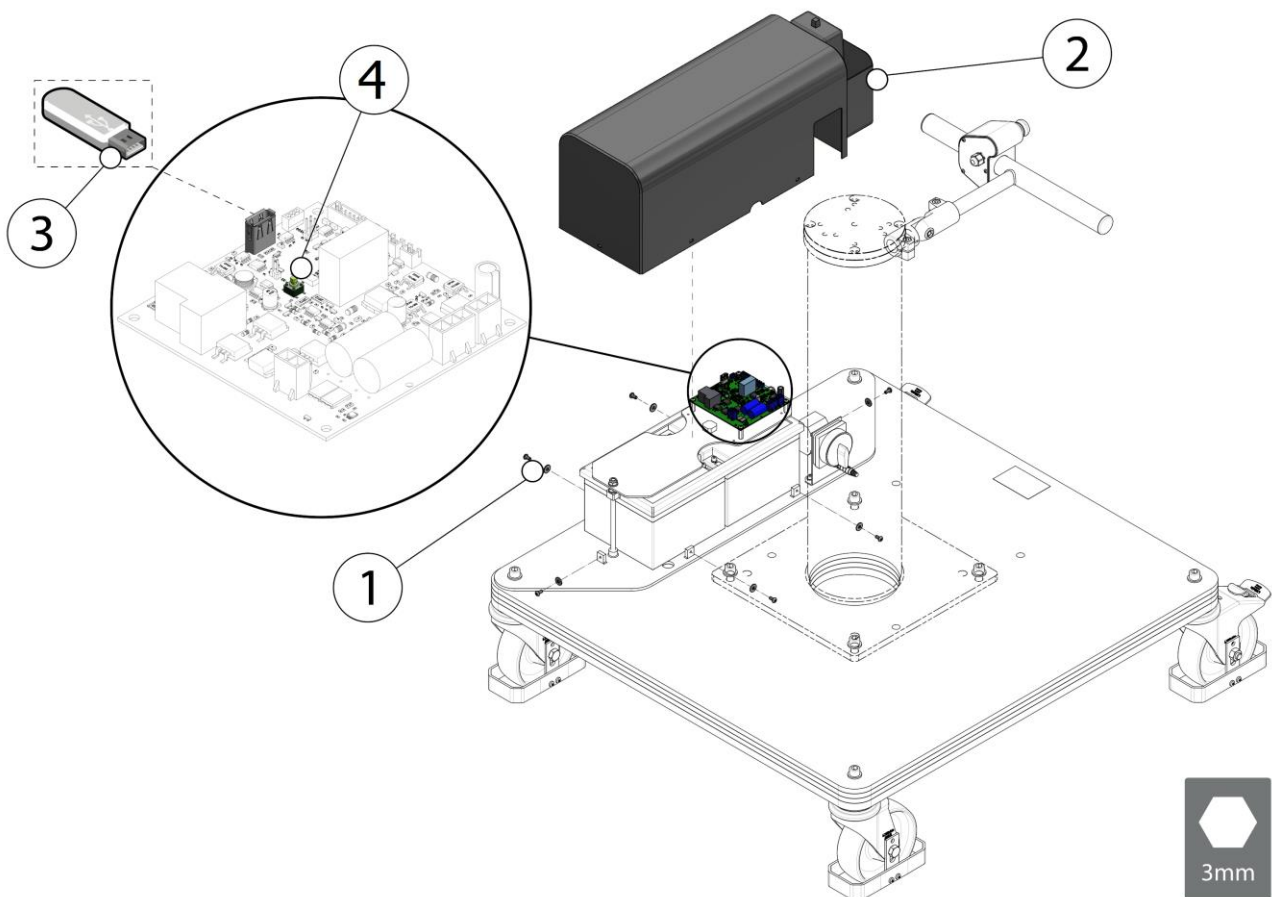

⁶ The trolley must be turned on and activated, if it is in low power mode the update will not be performed correctly.

9 FREQUENT PROBLEMS

9.1 PROBLEM: ENGINE WON'T START

Possible Causes	Solution
1.- Battery discharged	= Charging the battery. If it does not charge, replace it [See REPLACING THE BATTERY page 24] (Try a different charger first)
2.- Maximum load exceeded	= Reduce load
3.- Push button broken	= Check mechanism and wiring
4.- Electrical failure of the motorised wheel	= Contact the manufacturer
5.- Emergency stop pressed	= Unlock emergency stop [See OPERATION page 19].

9.2 PROBLEM: THE WHEEL SKIDS

Possible Causes	Solution
1.- The wheel does not pull	= Adjust the spring [See ADJUSTING THE SPRING page 18].
2.- Low soil adhesion	= Contact the manufacturer to change the wheel model

9.3 PROBLEM: WRONG SPEED

Possible Causes	Solution
1.- Motorised wheel system failure	= Contact the manufacturer

9.4 PROBLEM: OVERCURRENT

Possible Causes	Solution
1.- The wheel skids	= Exit the error mode by pressing one of the start buttons for 3 seconds and [See PROBLEM: THE WHEEL SKIDS page 26].
2.- Maximum load exceeded	= Exit the error mode by pressing one of the start buttons for 3 seconds and [See PROBLEM: ENGINE WON'T START page 26].

9.5 PROBLEM: SHORT-CIRCUIT

Possible Causes	Solution
1.- Faulty cable =	Exit the error mode by pressing one of the start buttons for 3 seconds. Disconnect the motor terminals, isolate them and switch on the trolley. If the error persists, replace the cables.
2.- Faulty electric wheel =	Exit the error mode by pressing one of the start buttons for 3 seconds. Disconnect the motor terminals, isolate them and switch on the trolley. If the error persists, replace the wheel.

9.6 PROBLEM: FAULTY BATTERIES

Possible Causes	Solution
1.- Losses or cracks (abnormal appearance) =	Contact the manufacturer.
2.- Reduced battery capacity =	If it continues after 24 to 48 hours of equalisation charge, please contact the manufacturer.

9.7 PROBLEM: NO BATTERY

Possible Causes	Solution
1.- Depleted battery =	When the electric trolley runs out of battery, the wheel is mechanically locked and to move the trolley manually it is necessary to use the mechanical wheel unlocking key. Screw the key clockwise until the wheel is unlocked. Move the trolley to the battery recharging area equipment [See RECHARGING THE BATTERY page 20]. Remove the mechanical unlocking key from the wheel.
2.- Old battery =	To move the carriage manually it is necessary to use the mechanical wheel unlocking key. Screw the key clockwise until the wheel is unlocked. Follow the steps described in the manual to replace the battery [See REPLACING THE BATTERY page 24].

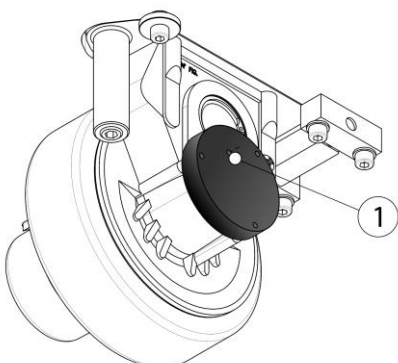

10 WIRING



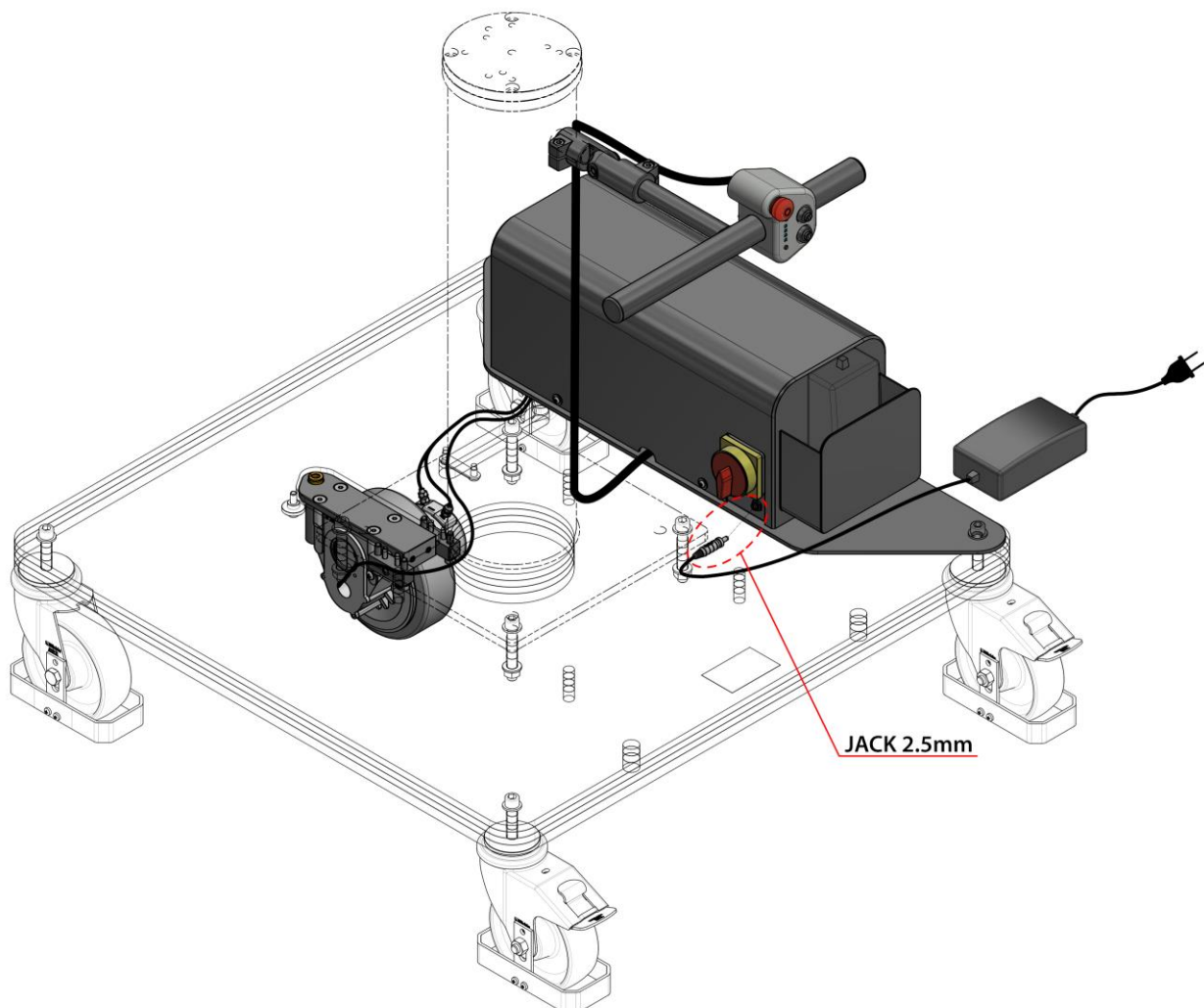



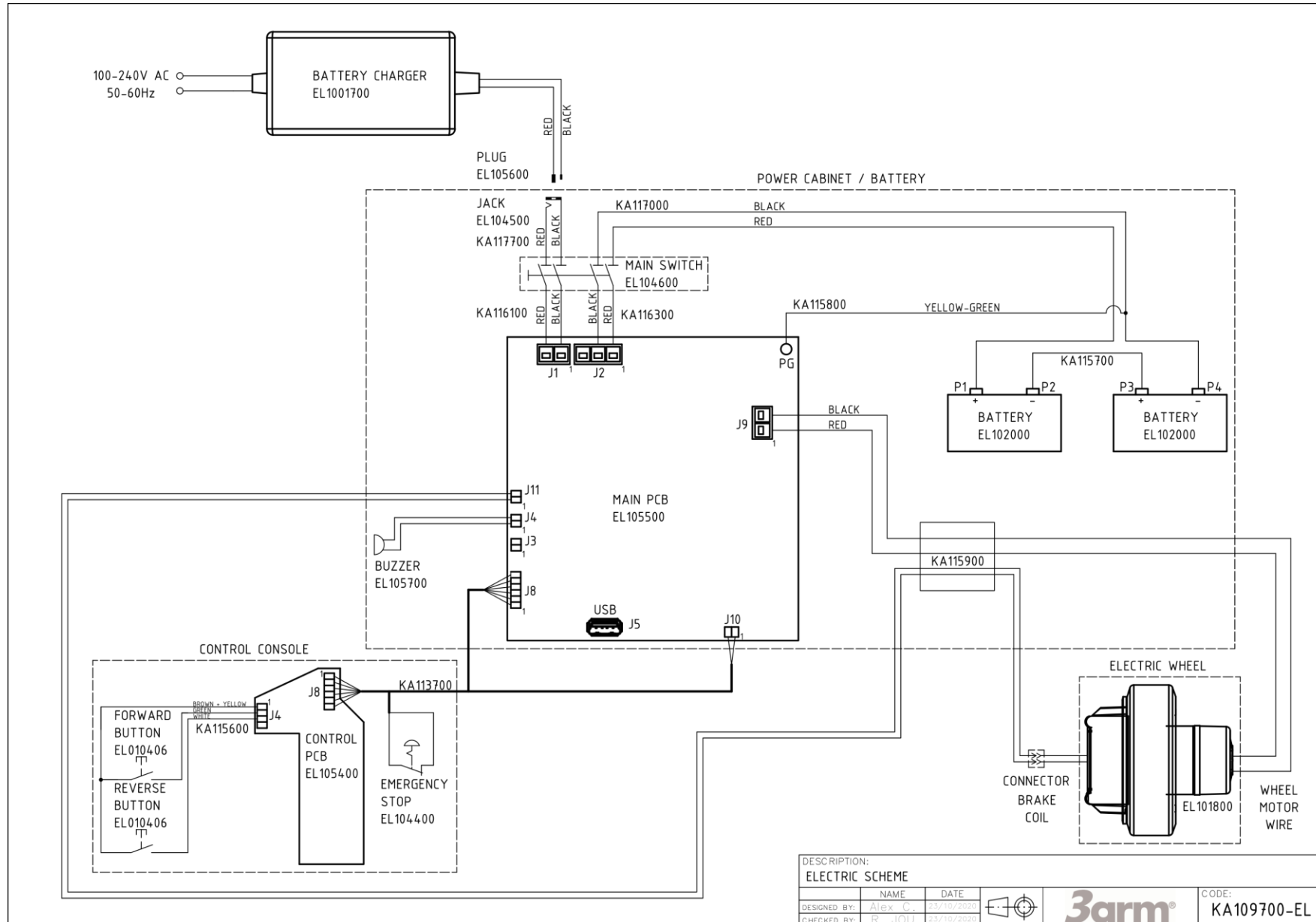

10.1 MAIN WIRING

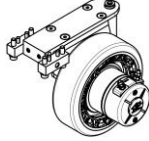

10.2 ELECTRICAL DIAGRAM

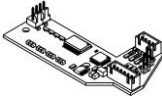
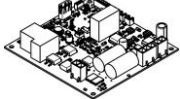

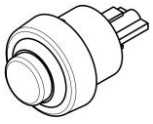
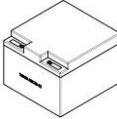
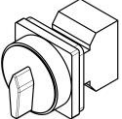
11 SPARE PARTS

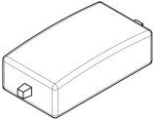
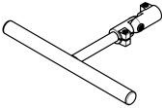
CODE	DESCRIPTION	PICT.	CODE	DESCRIPTION	PICT.
KA109800	ELECTRIC WHEEL		CM145900	WHEEL 150	
EL10060C	ELECTRIC WHEEL BRAKE		CM145800	150 WHEEL WITH BRAKE	
EL105400	LEDS PLATE		EL105500	WHEEL PLATE	
EL104400	EMERGENCY STOP		MO505104	MARQUARDT 5000 IP54 PUSHBUTTON	
EL102000	BATTERY		EL104600	MAIN SWITCH	
AC006506	EYEBOLT		EL101700	CHARGER	
CL0050A4R	HANDLE WITH JOINT				

12 ACCESSORIES

Caution: not all the accessories shown below are compatible. Check the compatibility table [See [COMPATIBLE ACCESSORIES](#) page 34].

TROLLEY

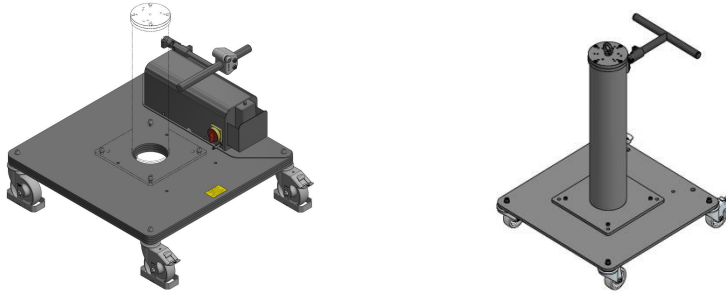

To move the work unit.
It has four orientable wheels.

DESCRIPTION	DIMENSIONS	
Trolley 700	700 x 700 mm	27 9/16" x 27 9/16"
Trolley 900	900 x 900 mm	35 7/16" x 35 7/16"
Electric trolley	900 x 900 mm	35 7/16" x 35 7/16"
Electric trolley	800 x 800 mm	31 1/2" x 31 1/2"

FIXED COLUMN

To secure to the floor using four metal studs.

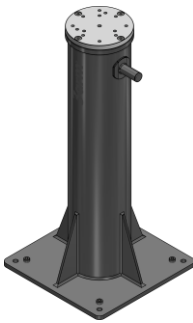

DESCRIPTION/DIMENSIONS	
Column 62mm	2 1/2"
Column 112mm	4 3/8"
Column 162mm	6 3/8"
Column 275mm	10 7/8"
Column 375mm	14 3/4"
Column 450mm	17 3/4"
Column 635mm	25"
Column 740mm	29 1/8"
Column 850mm	33 1/2"
Column 1100mm	43 1/4"
Column 1350mm	53 1/8"
Column 1600mm	63"

LIFT / PR LIFT



It consists of a telescopic column and a pneumatic cylinder with anti-rotation.



DESCRIPTION	VERTICAL TRAVEL
Lifter 300	300 mm – 11 7/8"
Lifter 500	500 mm – 19 7/8"
Lifter 750	750 mm – 29 17/32"
Lift 300 PR	300 mm – 11 7/8"
Lift 550 PR	550 mm – 21 5/8"
Lifter 750 PR	750 mm – 29 17/32"

D63 / D100 COLUMN



Pneumatic lift. The vertical position can be locked at any point, it has a pneumatic cylinder. It can be secured to the ground, on a trolley or on the ground rail to have movement on two shafts.



DESCRIPTION	VERTICAL TRAVEL
Column 1500 D63	940 mm – 37"
Column 2000 D63	1440 mm – 56 11/16"
Column 2500 D63	1940 mm – 76 3/8"
Column 1500 D100	999 mm – 39 7/16"
Column 2000 D100	1455 mm – 57 5/16"
Column 2500 D100	1999mm – 78 11/16"

EXTENSION

(1)



Extender that enables the arm's working area to be increased. It can also be installed on other accessories, such as column, lift, beam, etc.

CODE	DESCRIPTION	ADDITIONAL WORK AREA
ER0010C0	Extension 500 (1)	500 mm – 19 11/16"
ER200500	Extension 600	600 mm – 23 5/8"
ER000100	Extension 1000 (2)	1000 mm – 39 3/8"

(2)



BASE ROTATION LIMITER



Support that limits the rotation of the radial arm of the equipment. The stops can be moved to adjust the range of rotation.

CODE	DESCRIPTION
LG000104	Rotation Limiter

ROTATION LIMITER

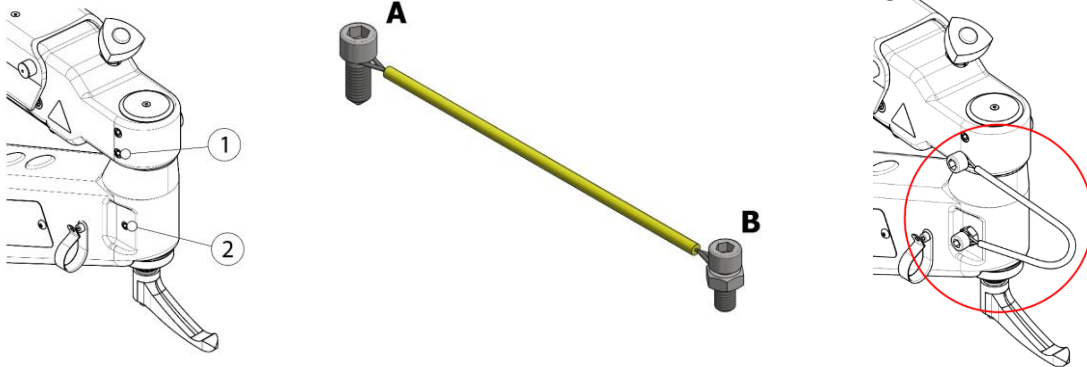

The rotation limiter is a flexible reinforced steel cable that limits the rotational movement of the front arm, to a maximum of 1 turn, with an added margin of 10% in each rotation direction.

To assemble it, unscrew the screws/studs (1) and (2) that come in the arm from the factory, and replace them with screws "A" and "B" in the KIT.

Screw "A" (M12) will go in position 1 and screw "B" (M10) in position 2.

CODE	DESCRIPTION
LG100600	Rotation limiter assembly

12.1 COMPATIBLE ACCESSORIES

ACCESSORIES	ELECTRIC TROLLEY
RADIAL EXTENSION	⊘
TROLLEY	⊘
FIXED / PR COLUMN	●
PNEUMATIC / PR TELESCOPIC LIFT	⊘
AIR LIFT D63 / D100	●
ROTATION LIMITER	⊘
BASE ROTATION LIMITER	⊘

- = Compatible
- ⊘ = NOT Compatible
- * = Please ask

12.2 COMPATIBLE EQUIPMENT

EQUIPMENT	ELECTRIC TROLLEY
ROSCAMAT	● ⁷
3ARM	● ⁷
MANIPULATOR	● ⁷

13 WARRANTY

See attached guarantee document.

⁷ Pre-installation of a fixed column/PR or a pneumatic lift D63/D100 is required

14 PACKAGING, TRANSPORT AND DISASSEMBLY GUIDELINES

14.1 PACKAGING

Follow the instructions below for packing the equipment for location changes or shipments for repair and maintenance.

14.1.1 Preparatory measures

The equipment must be placed out of service. Assembling the "transport safety elements" will prevent movement during transport and thus possible damage to the installation.

14.1.2 Choice of packaging

For long transport distances, the components of the production installation must be packed in such a way that they are protected from atmospheric conditions.

14.1.3 Inscription on the packaging

Observe the specific provisions of the country in which the equipment is transported. In fully closed packaging, an indication must be placed on the packaging indicating where the top is.

14.1.4 Packaging procedure

Place the components of the machine on manufactured wooden pallets. Use lashing straps to ensure the components are secured against possible falls. Attach all the technical documentation that must accompany the machine.

14.2 TRANSPORT

The following data must be taken into account for transport.

- ✓ External dimensions (width x depth x height), approx.: 982 x 982 x 667 mm
- ✓ Total weight depending on the segment: minimum approx. 258 kg

14.3 DISASSEMBLY

- ✓ The equipment must be taken out of service by duly trained and authorised personnel.
- ✓ The machine must be dismantled taking the safety instructions, waste disposal and recycling into account.
- ✓ Protect the environment. The machine must be disposed of pursuant to current regulations and guidelines on safety, noise prevention, environmental protection and accident prevention.

CE STATEMENT OF COMPLIANCE

The manufacturer:

Company: TECNOSPIRO MACHINE TOOL, S.L.U.
Address: P.I. Pla dels Vinyats I, s/n nau 1
City: Sant Joan de Vilatorrada
Country: Spain - EU

Declares that this product:

Name: Electric Trolley
Serial number: From 001 - 026

It is classified as a machine in accordance with Machinery Directive 2006/42/EC and to which this Declaration refers, is in conformity with the following European EC Directives, and their applicable Essential Health and Safety Requirements (EHSRs):

ROSCAMAT®

2006/42/EC – Machinery Directive

2014/30/EC – Electromagnetic Compatibility Directive

2014/35/EC – Low-Voltage Directive

2011/65/EC – Directive on the Restriction of the Use of Certain Hazardous Substances in Electronic and Electrical Equipment

Authorized for documentation:

Mr. Ramon Jou Parrot of TECNOSPIRO MACHINE TOOL, S.L.U.

TECNOSPIRO
MACHINE TOOL SL



Sant Joan de Vilatorrada, Wednesday, October 25, 2023

Ramon Jou Parrot, Technical Director

3arm® **ROSCAMAT®**

TECNOSPIRO
MACHINE TOOL SLU